

OPW 106 Identification Marker

OPW 106 Identification Markers are used to identify the grade product stored in underground tanks. These markers are easily set in concrete, and once set, are permanent. The letter plate is recessed into the face of the base and fastened with two screws. The raised letters are easy to change when the product is changed. Letters available are P, R, U, SU, X, DL. Numbers 1, 2, 3, 4.

OPW 107 Nameplate Holder

OPW 107 Nameplate Holders, when secured to storage tank fill pipes, provide a method to permanently identify the product in the tanks.

Spill Container Product Identification Tags

OPW Color-Coded Spill Container Tags positively and conspicuously identify tanks, preventing costly and dangerous product drop mistakes. Simply "peel and stick" the high-visibility color inserts into the special recesses cast into the spill container cover.

Matching bucket tags, supplied with tie wraps, are permanently affixed inside the spill container to help prevent covers from getting switched.

Materials

Base and anchor shank: Aluminum

Letter Plate: Cast aluminum

Screws (2): Brass



Ordering Specifications

Product #	Fuel Type	lbs.	kg
106DL-0095	Diesel	.43	.20
106P-0150	Premium	.41	.19
106R-0175	Regular	.44	.20
106SU-0185	Super Unleaded	.43	.20
106U-0125	Unleaded	.44	.20

Product #	Fuel Type	lbs.	kg
106UP-0125	Unleaded "Plus"	.44	.20
106N-1100	I.D. Marker #1	.44	.20
106N-2200	I.D. Marker #2	.44	.20
106N-3300	I.D. Marker #3	.44	.20
106N-4400	I.D. Marker #4	.44	.20

Replacement Parts

Part #	Description
H01629M	Screw
H02211M	106DL Letter Plate
H11775M	106FL Letter Plate
H01780M	106P Letter Plate
H01781M	106R Letter Plate

Part #	Description
H10122M	106SU Letter Plate
H07084M	106U Letter Plate
H10899M	106UP Letter Plate

Materials

Plate: Plated steel

Straps: Plated steel

Ordering Specifications

Product #	in.	mm	lbs.	kg
107-0300	4	102	.39	.18

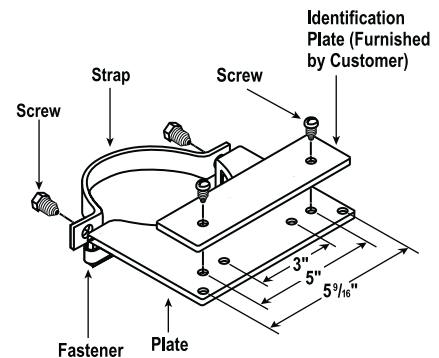

Features

- ◆ Unique Fiberglass Embedment Process - ensures that the color identifiers won't scratch, crack, peel, weather or fade, even in gasoline and the harshest of environments.
- ◆ Compatible - with all OPW 1-2100 Series Spill Containers, including aluminum, cast iron, sealable cover and 101BG Composite Cover models. Also compatible with 111 Series, Multi-Port Spill Containers and OPW 104FG/104C Manhole Covers.
- ◆ Available in All API Product I.D. Designations.



Product	Product Designations	Cover I.D. Tag Product #	Bucket I.D. Tag Product #
Regular Unleaded	White w/Black Cross	1TAG-1000	1TAG-1010
Mid-Grade Unleaded	Blue w/White Cross	1TAG-2000	1TAG-2010
Premium Unleaded	Red w/White Cross	1TAG-3000	1TAG-3010
Diesel	Yellow Hex	1TAG-4000	1TAG-4010
Vapor Recovery	Solid Orange	1TAG-7000	1TAG-7010
85% Ethanol (E85)	Bronze Diamond Black letters (E85)	1TAG-CE85	1TAG-BE85
Ultra Low Sulfur	Yellow Hex/Black letter (U)	1TAG-4200	